

103-H7123-1711.B

Dimensions (Unit:mm)

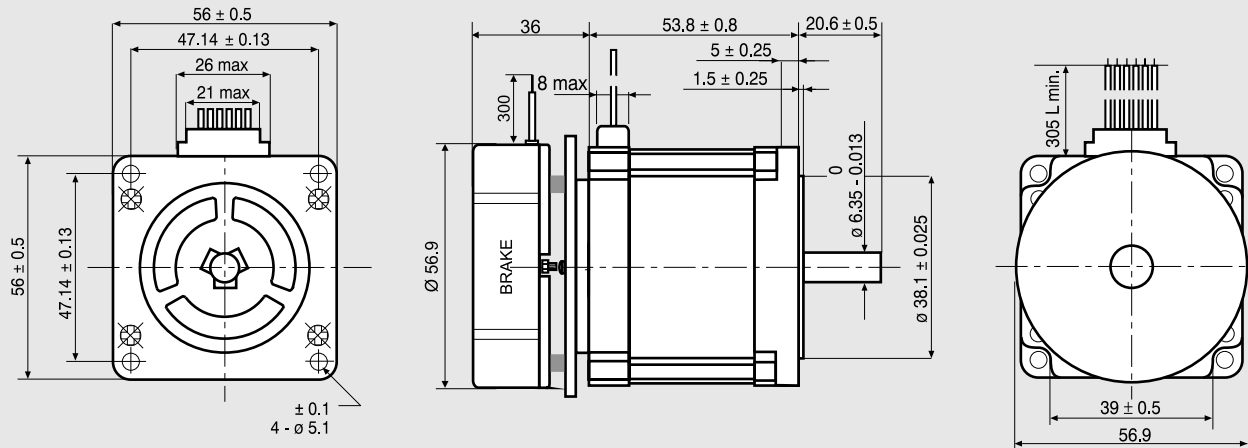

SANYO DENKI MOTOR FEATURES

MODEL		103-H7123-1711.B
SANYO DENKI MOTOR CODE		103-H7123-1711
BASIC STEP ANGLE		$1.8^\circ \pm 0.09^\circ$
BIPOLAR PARALLEL CURRENT	(Amp)	4.0
UNIPOLAR PARALLEL CURRENT	(Amp)	
RESISTANCE	(Ohm)	0.41
INDUCTANCE	(mH)	1.6
BIPOLAR HOLDING TORQUE	(Ncm)	110
UNIPOLAR HOLDING TORQUE	(Ncm)	
ROTOR INERTIA	($\text{Kgm}^2 \times 10^{-7}$)	210
THEORETICAL ACCELERATION	($\text{rad} \times \text{sec.}^{-2}$)	50000
BACK E.M.F.	(V/Krpm)	20
MASS	(Kg)	1.15
LEADS CODE		V

TORQUE/SPEED CURVE

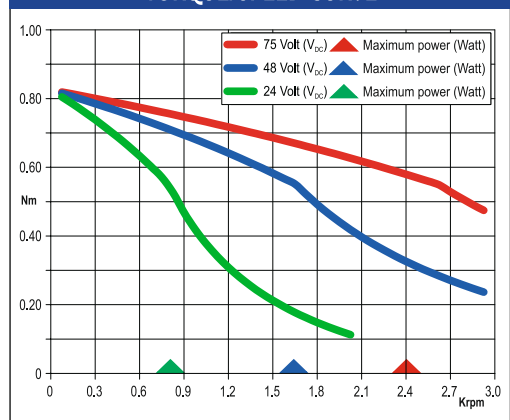

BRAKE FEATURES

STATIC TORQUE	(Nm)	4.0
DUTY CYCLE		50% max.
VOLTAGE	(Volt)	24 VDC
POWER	(W)	11
RELEASE TIME	(ms)	300



Suggested R.T.A. drive series: BSD, CSD, NDC, ADW, HGD, FLEX-DRIVE



R.T.A. s.r.l.
Via E. Mattei - Fraz- Divisa
27020 Marcignago (PV) (Italy)
T +39.0382.929.855
F +39.0382.929.150
www.rta.it

R.T.A. Deutschland GmbH
Bublitz Strasse 34, 40599
Duesseldorf (Germany)
T +49.211.749.668.60
F +49.211.749.668.66
www.rta-deutschland.de

R.T.A. IBERICA
C/Generalitat 22, Local 1
08850 Gava - Barcelona (Spain)
T +34 936.388.805
F +34 936.334.595
www.rta-iberica.es

R.T.A. INDIA Pvt
Teerth Business Center 3rd Floor, Unit No. 7,
Block EL-15, MIDC Bhosari Pimpri-Chinchwad,
Pune 411026 (India)
Tel. +91 9422507445
www.rta-india.in