

SM 2862-5125.B

Dimensions (Unit:mm)

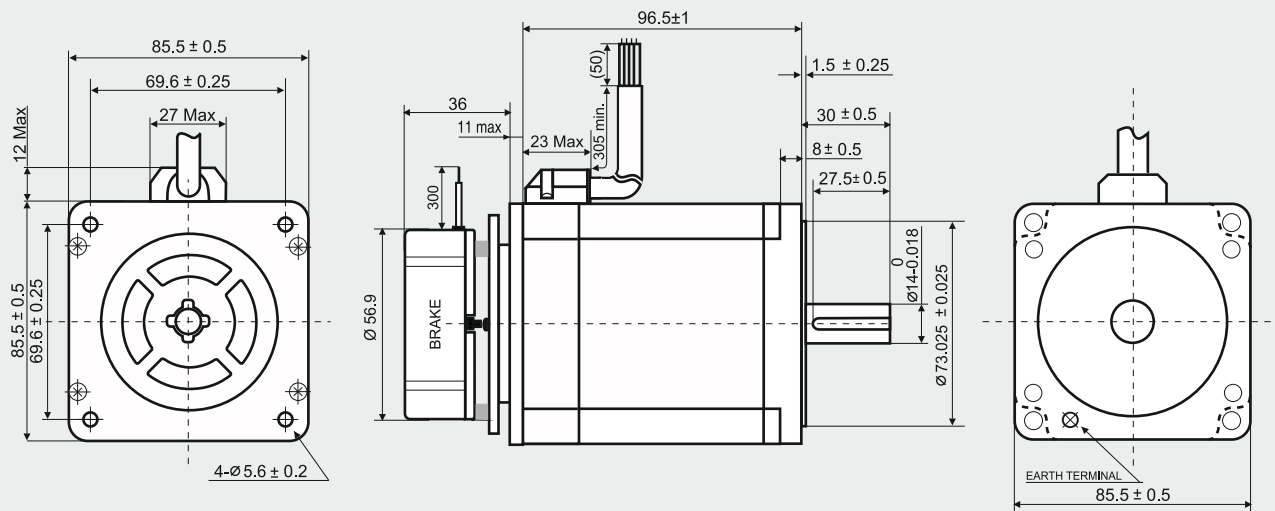

SANYO DENKI MOTOR FEATURES

MODEL	SM 2862-5125.B
SANYO DENKI MOTOR CODE	SM 2862-5125
BASIC STEP ANGLE	1.8° ± 0.09°
BIPOLAR PARALLEL CURRENT (Amp)	4.0
RESISTANCE (Ohm)	0.83
INDUCTANCE (mH)	6.4
BIPOLAR HOLDING TORQUE (Ncm)	700
ROTOR INERTIA (Kg ^m × 10 ⁻⁷)	3000
THEORETICAL ACCELERATION (rad × sec. ⁻²)	23300
BACK E.M.F. (V/Krpm)	175
MASS (Kg)	3.4
INTERNATIONAL STANDARDS	UL, CSA
INSULATION VOLTAGE (V)	250 VAC (350 VDC)
PROTECTION DEGREE - INSULATION CLASS	IP43 - F
LEADS CODE	V

TORQUE/SPEED CURVE

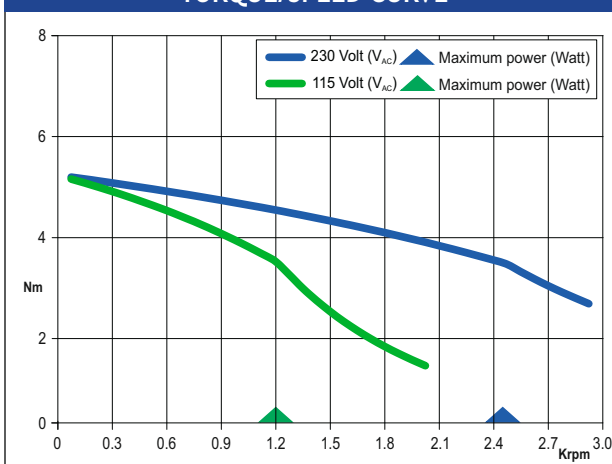

R.T.A. s.r.l. PAVIA (ITALY) SANYO DENKI CO., Ltd (JAPAN)

BRAKE FEATURES

STATIC TORQUE (Nm)	4.0
DUTY CYCLE	50% max.
VOLTAGE (Volt)	24 VDC
POWER (W)	11
RELEASE TIME (ms)	300



Suggested R.T.A. drive series: 230 Vac X-PLUS



R.T.A. s.r.l.
Via E. Mattei - Fraz- Divisa
27020 Marcignago (PV) (Italy)
T +39.0382.929.855
F +39.0382.929.150
www.rta.it

R.T.A. Deutschland GmbH
Bublitzer Strasse 34, 40599
Duesseldorf (Germany)
T +49.211.749.668.60
F +49.211.749.668.66
www.rta-deutschland.de

R.T.A. IBERICA
C/Generalitat 22, Local 1
08850 Gava - Barcelona (Spain)
T +34 936.388.805
F +34 936.334.595
www.rta-iberica.es

R.T.A. INDIA Pvt
Teerth Business Center 3rd Floor, Unit No. 7,
Block EL-15, MIDC Bhosari Pimpri-Chinchwad,
Pune 411026 (India)
Tel. +91 9422507445
www.rta-india.in